

SITE PLAN
SCALE 1:1000

BOREHOLE POSITION

POINTS	X	Y
BH1	3198421.931	89322.871
BH2	3198445.659	89326.280
BH3	3198469.558	89329.369
BH4	3198493.421	89332.639

CONTROL POINTS WGS 84

POINTS	X	Y	Z
BPA	3198386.686	89312.390	895.154
BPB	3198516.921	89302.765	895.375
BPC	3198493.605	89353.532	894.760
BPD	3198409.844	89324.403	894.294

DRAWING INDEX

DRAWING No.	TITLE OF DRAWING
4101 /01	GENERAL ARRANGEMENT A (SITE PLAN, BRIDGE DATA BLOCK & BOREHOLE DATA)
4101 /02	GENERAL ARRANGEMENT B (DECK PLAN, FOUNDATION PLAN & ELEVATION VIEW)
4101 /03	GENERAL ARRANGEMENT C (ROAD LONGITUDINAL SECTION)
4101 /04	GENERAL ARRANGEMENT D (PIER DETAILS)
4101 /05	GENERAL ARRANGEMENT E (ABUTMENT & BARRIER DETAIL)

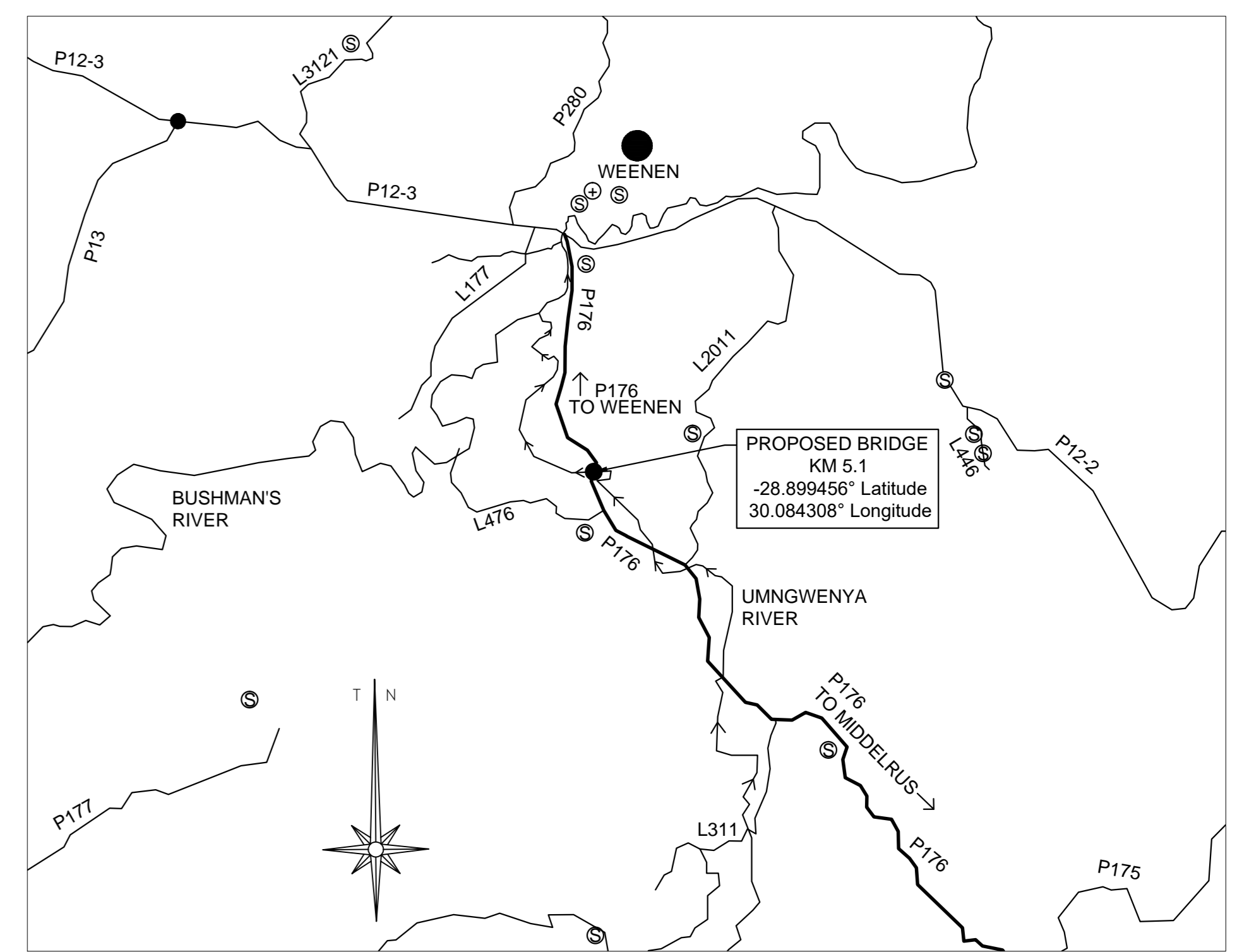

LOCALITY PLAN
SCALE 1:50 000

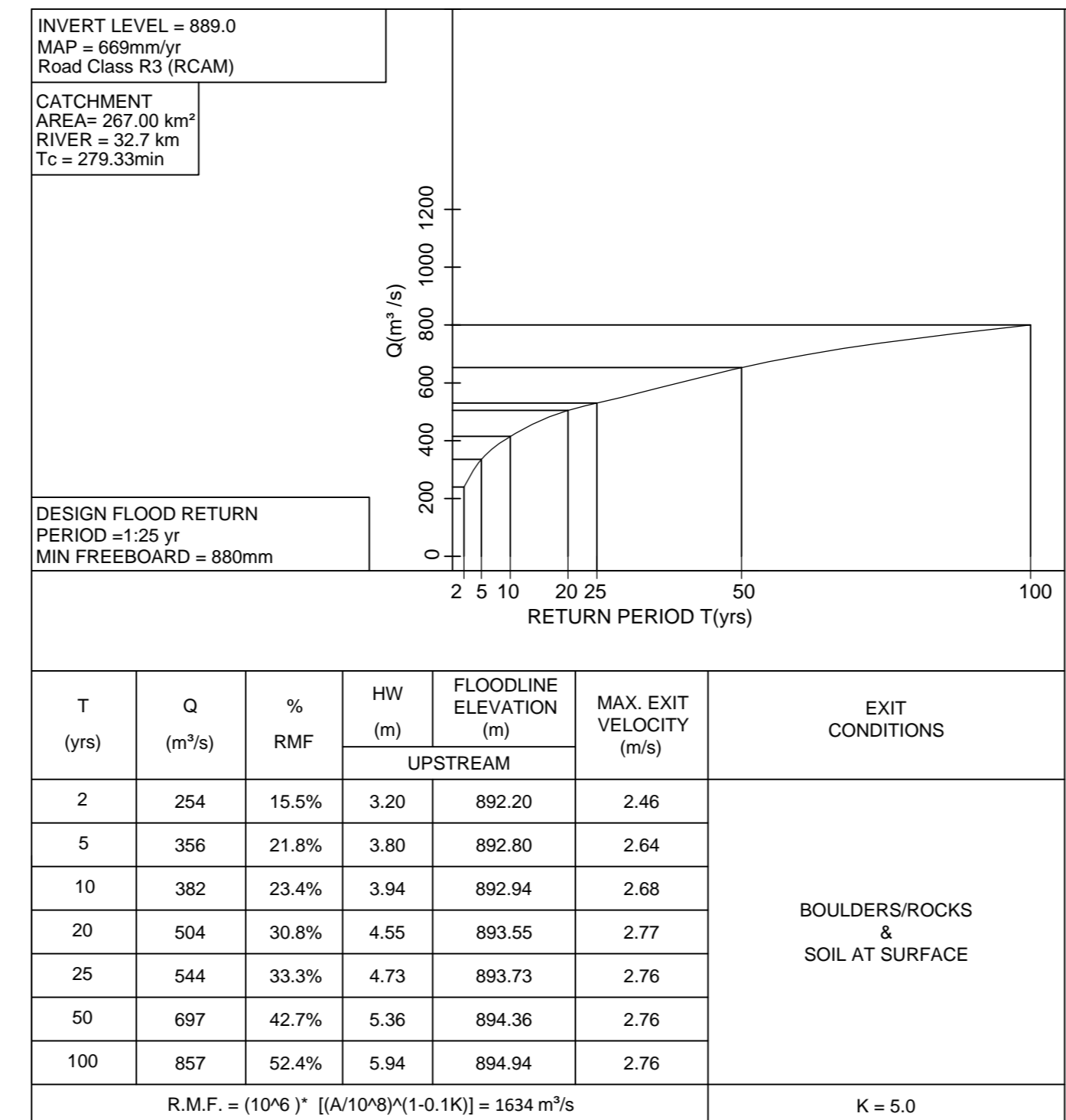

BRIDGE DATA BLOCK

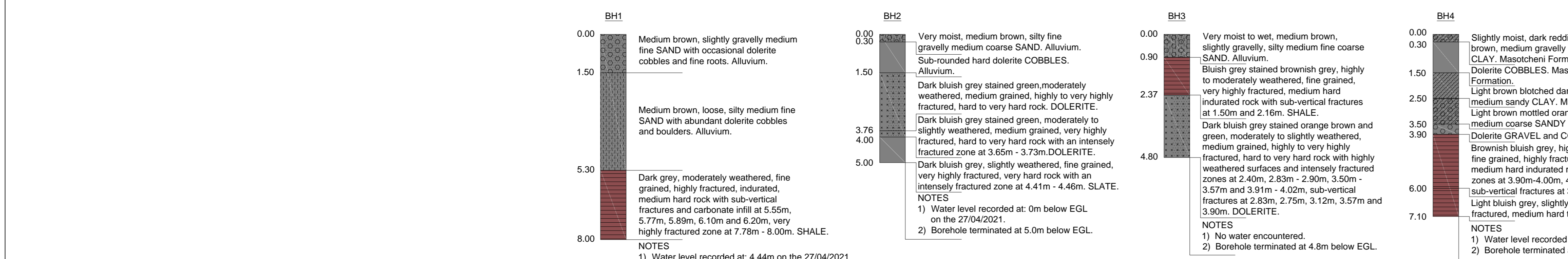
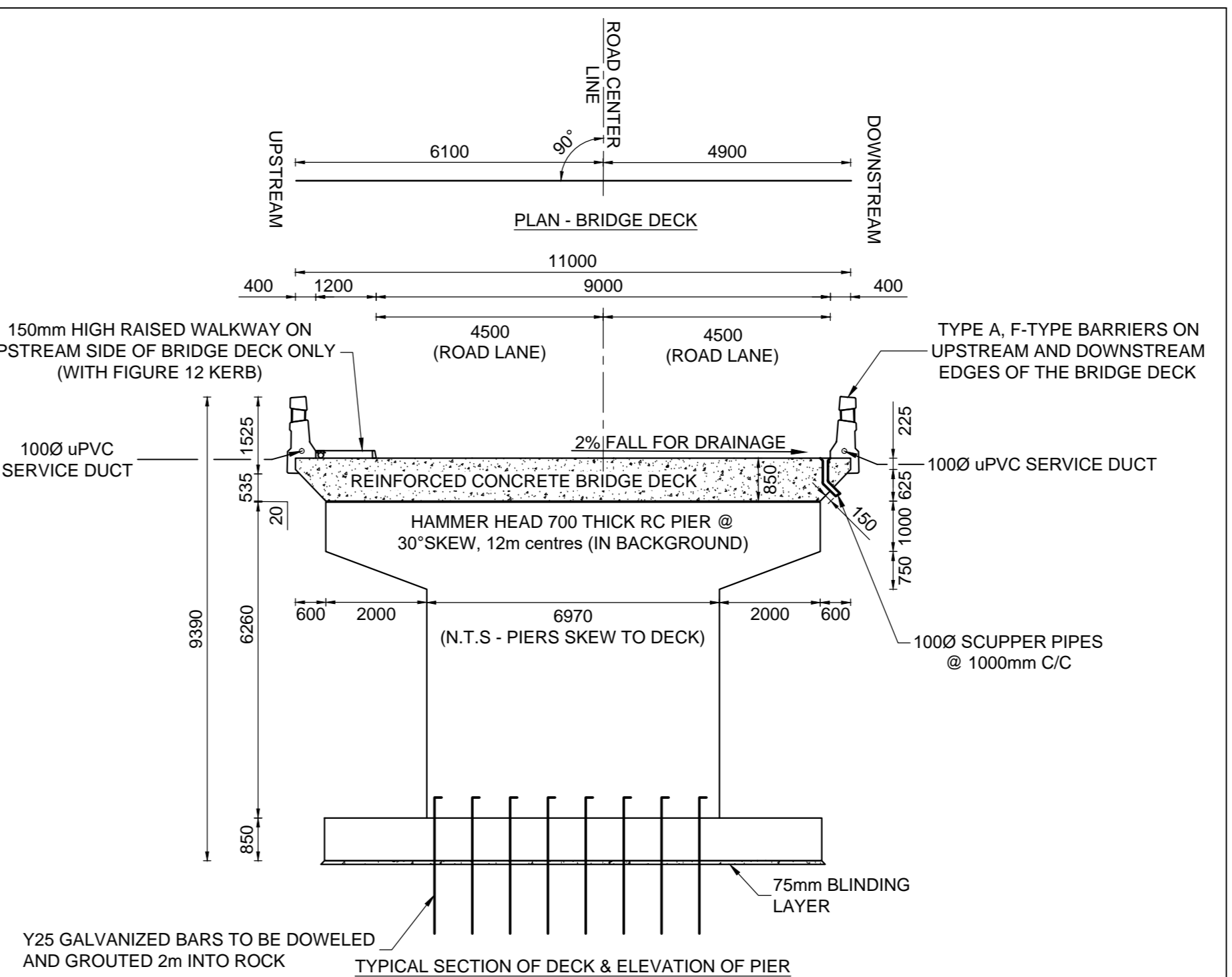

BOREHOLE PROFILES
SCALE 1:100

GENERAL NOTES:

- ALL WORK AND MATERIALS SHALL COMPLY WITH STANDARD SPECIFICATIONS FOR ROAD AND BRIDGE WORKS 1987 (CSRA).
 - LOADING : DESIGN LOADING IS IN ACCORDANCE WITH TMH 7 PARTS 1 & 2 AS AMENDED JULY 1991 & KZN DOT STRUCTURES DESIGN MANUAL.
 - TRAFFIC : NA
 - EARTH : DENSITY OF BACKFILL - 2000kg/m³
HORIZONTAL EARTH PRESSURE - 7.8kPa PER METRE DEPTH
MAX. FOUNDATION PRESSURE APPLIED - SLS 750kPa
 - CONCRETE CLASS :
15/19 (15MPa) : BLINDING
30/19 (30MPa) : ABUTMENTS, PIERS & DECKS
 - REINFORCING STEEL : ALL REINFORCEMENT SHALL COMPLY WITH SABS 920-1985. REINFORCEMENT SHALL BE BENT IN ACCORDANCE WITH SABS 82-1976 INCLUDING AMENDMENT NO. 1-1986.
 - CONCRETE COVER TO REINFORCEMENT : 50mm TO ABUTMENTS, PIERS & DECKS
 - CHAMFERS : ALL SHARP CONCRETE EDGES TO BE CHAMFERED 25mm UNLESS OTHERWISE SHOWN.
 - FORMED CONCRETE SURFACE FINISHES :
CLASS F1 : CONCEALED SURFACES (ROUGH)
CLASS F2 : VISIBLE SURFACES (SMOOTH)
 - UNFORMED CONCRETE SURFACE FINISHES :
CLASS U1 : CONCEALED SURFACES
CLASS U2 : VISIBLE SURFACES
 - THE RIVER NAME (UMNGWENYA) IS TO BE REBATED 10mm DEEP IN 100mm CAPITAL LETTERING WITH THE YEAR OF CONSTRUCTION IN 75mm NUMBERING, CENTRALLY ORIENTATED BELOW THE NAME. THE NAME AND DATE IS TO BE HORIZONTALLY PLACED, CENTRALLY ORIENTATED ON THE LEFT HAND APPROACH END BLOCK. ON EACH END OF THE F-TYPE BALUSTRADE, ABOVE THE GUARDRAIL RECESS LEVEL, THE BRIDGE NUMBER (3921) IS TO BE REBATED 10mm IN 75mm NUMBERING INTO THE TOP OF THE SLOPING HORIZONTAL SURFACE. ALL NUMBERS AND LETTERING IS TO BE CAREFULLY PAINTED WITH TWO COATS OF BLACK ALKALI RESISTANT PAINT.
 - DESIGN BEARING PRESSURES:
PERMISSIBLE BEARING PRESSURE: - HARD TO VERY HARD ROCK - 750 KPa to 1000 KPa
ABUTMENTS - HARD TO VERY HARD ROCK - 750 KPa to 1000 KPa
PIER - HARD TO VERY HARD ROCK - 750 KPa to 1000 KPa
(REFER TO GEOTECHNICAL REPORT PREPARED BY GEOSURE REF "060-21.R03")
- ADDITIONAL NOTES FOR F-TYPE BARRIERS:
- CLASS OF CONCRETE SHALL BE 30/19 (MPa/mm) UNLESS OTHERWISE SPECIFIED.
 - ALL CORNERS TO BE CHAMFERED WITH 20mm X 20mm UNLESS OTHERWISE SPECIFIED. THE TOP CORNERS OF THE PARAPET WALL ARE TO BE ROUNDED WITH A 20mm RADIUS
 - CONSTRUCTION JOINTS BETWEEN SEGMENTS TO BE 20mm THICK FILLED WITH POLYSULPHIDE SEALANT OR SIMILAR APPROVED. JOINTS ARE TO LINE UP WITH EXISTING 20mm JOINTS IN THE BRIDGE DECK.
 - ALL STEEL REINFORCING TO BARRIERS SHALL HAVE A MINIMUM CONCRETE COVER OF 40mm.
 - SURFACE FINISHES ON ALL EXPOSED SURFACES TO BE CLASS F3 FOR STEEL SHUTTER FINISHES AND CLASS U3 FOR STEEL TROWEL FINISHES.
 - SHALL COMPLY WITH SANS 920: 1985. HIGH TENSILE BARS MIN YIELD STRESS MUST BE 450MPa AND MILD STEEL BARS MIN YIELD STRESS MUST BE 250MPa
 - BARRIER CAN WITHSTAND A 100KN FORCE APPLIED 700mm ABOVE THE ROAD SURFACE.
 - ALL WORK MUST BE DONE IN ACCORDANCE WITH THE "STANDARD SPECIFICATIONS FOR ROAD AND BRIDGE WORKS" (COLTO)
 - RIGHT HAND SIDE APPROACH END BLOCKS WILL BE A MIRROR IMAGE OF THE LEFT HAND SIDE APPROACH END BLOCKS.

FOR TENDER PURPOSES

Symbol	Date	Description	Checked	Signed
F	23-08-21	FOR DESIGN APPROVAL	S.S	
E	02-08-21	FOR DESIGN APPROVAL	S.S	
D	20-07-21	FOR DESIGN APPROVAL	S.S	
C	01-07-21	FOR DESIGN APPROVAL	S.S	
B	24-06-21	FOR DESIGN APPROVAL	S.S	
A	20-05-21	FOR APPROVAL PURPOSES	S.S	

AS BUILT

Supervising Engineer: _____ Date: _____

Supervising Authority: _____

Continued from:-
Designed by:- S.SHEOBALAK Pr Eng (202101742)

Continued on:-
Checked by:- P. NANKHOO Pr Eng (910350)

Design Plan No:-
Drawn by:- A. GUNAS

Long Section No:-
Checked by:- P. NANKHOO Pr Eng (910350)

Cross Section No:-
File Reference:- P176/6/4101/4



PROVINCE OF KWAZULU-NATAL
DEPARTMENT OF TRANSPORT



Chief Engineer: Structural Design

Head: Transport

MAIN ROAD P176
WEENEN TO MIDDELRSUS

GENERAL ARRANGEMENT A (SITE PLAN, BRIDGE DATA BLOCK & BOREHOLE DATA)

Staked km distance	Sheet 01
5.1KM	of 15
Scale	Plan No.:-
AS SHOWN	4101/01

4101/01

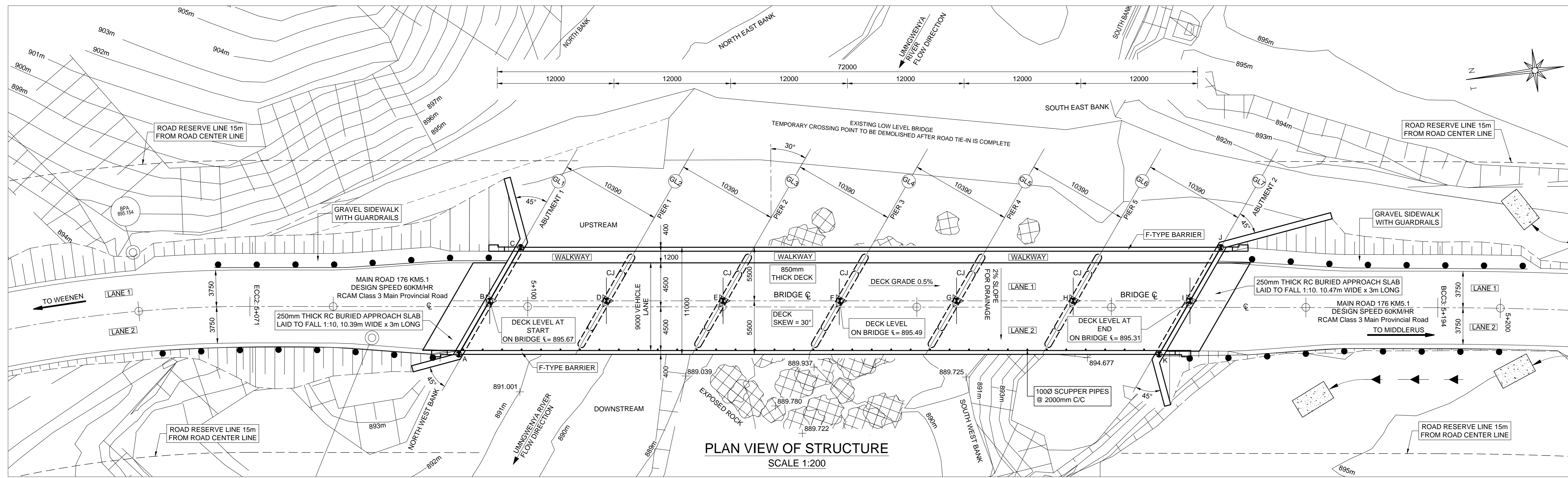

PLAN VIEW OF STRUCTURE
SCALE 1:200

SETTING OUT POINTS WGS 84				
POINTS	X	Y	Z- DECK T.O.C.	NAME
A	3198417.552	89327.159	895.560	ABUTMENT 1
B	3198421.016	89322.686	895.670	
C	3198425.329	89317.117	895.780	
D	3198432.907	89324.305	895.610	
E	3198444.797	89325.824	895.550	
F	3198456.687	89327.544	895.490	PIER 1
G	3198468.577	89329.163	895.430	PIER 2
H	3198480.467	89330.783	895.370	PIER 3
I	3198492.358	89332.402	895.310	PIER 4
J	3198496.670	89326.833	895.410	PIER 5
K	3198488.893	89336.875	895.190	ABUTMENT 2

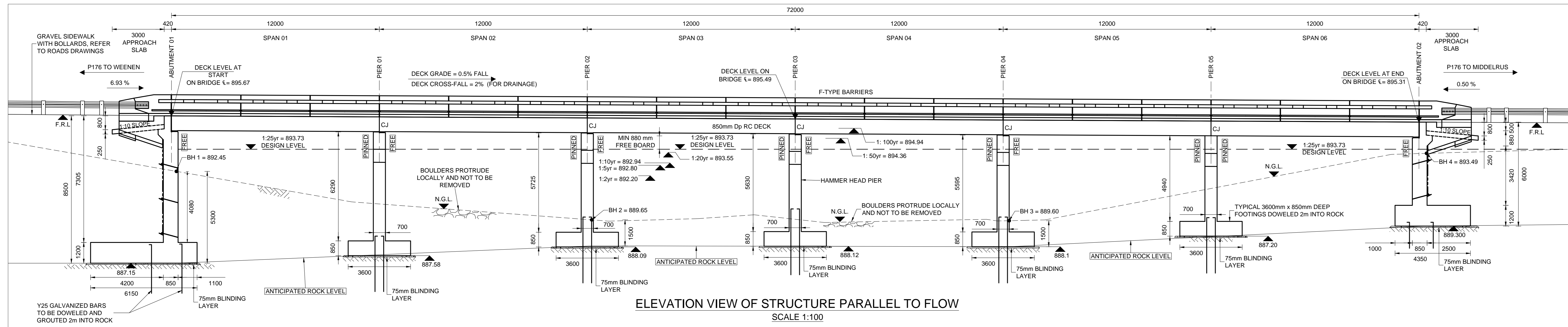

ELEVATION VIEW OF STRUCTURE PARALLEL TO FLOW
SCALE 1:100

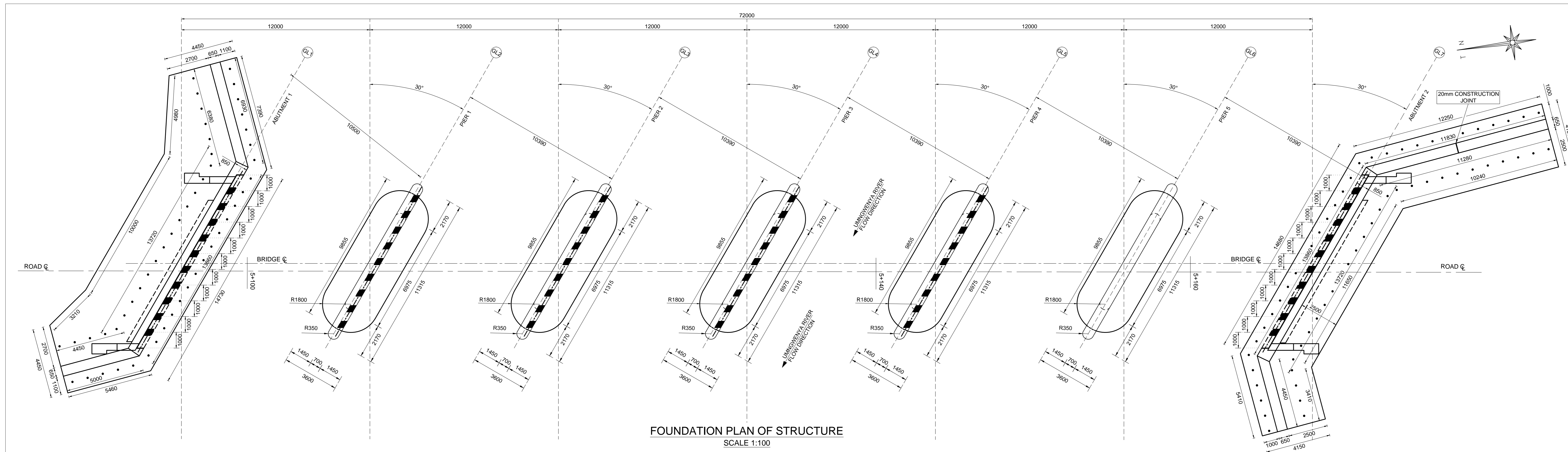

FOUNDATION PLAN OF STRUCTURE
SCALE 1:100

Symbol	Date	Description	Checked	Signed
E	02-08-21	FOR DESIGN APPROVAL	S.S	
D	20-07-21	FOR DESIGN APPROVAL	S.S	
C	01-07-21	FOR DESIGN APPROVAL	S.S	
B	24-06-21	FOR DESIGN APPROVAL	S.S	
A	20-05-21	FOR APPROVAL PURPOSES	S.S	

AS BUILT	
Supervising Engineer	Date
Supervising Authority	

Continued from:-	Designed by:- S.SHEOBALAK Pr Eng (202101742)
Continued on:-	Checked by:- P. NANKHOO Pr Eng (910350)
Design Plan No:-	Drawn by:- A. GUNAS
Long Section No:-	Checked by:- P. NANKHOO Pr Eng (910350)
Cross Section No:-	File Reference:- P176/6/4101/4



PROVINCE OF KWAZULU-NATAL
DEPARTMENT OF TRANSPORT



NANKHOO CONSULTING ENGINEERS
GREENHILLS OFFICE PARK, BLOCK ONE, 771, ROSSINGTON
1601, SANDHURST, DURBAN, KZN, SOUTH AFRICA
TEL: 031 201 2011 FAX: 031 201 2012
WWW.NANKHOOENGINEERS.CO.ZA

Chief Engineer : Structural Design

Head: Transport

MAIN ROAD P176 WEENEN TO MIDDELRUS
WGS 84:- -28.899456° Latitude
30.084308° Longitude
GENERAL ARRANGEMENT B (DECK PLAN, FOUNDATION PLAN & ELEVATION VIEW)

FOR TENDER PURPOSES	
Staked km distance	Sheet 02
5.1KM	of 15
Scale	Plan No.:-
AS SHOWN	4101/02

4101/02

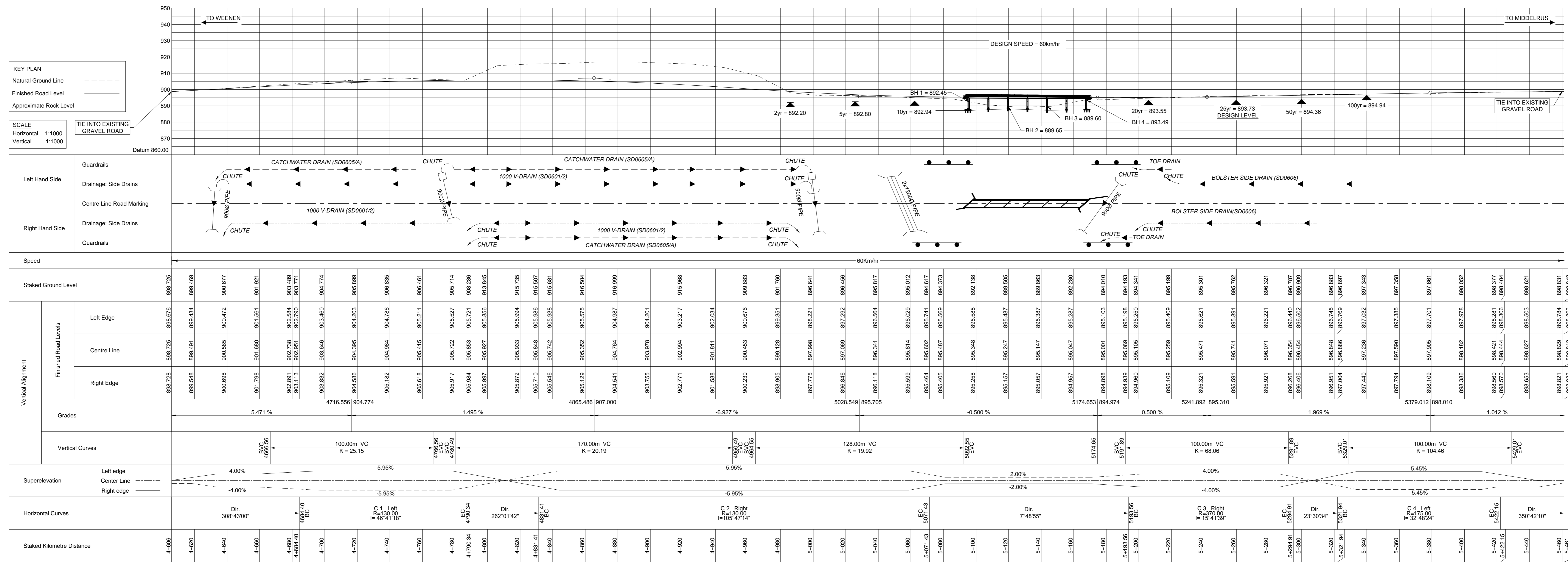

LONGITUDINAL SECTION - ROAD P176 KM 5.1
CHAINAGE 4+606m - 5+461m

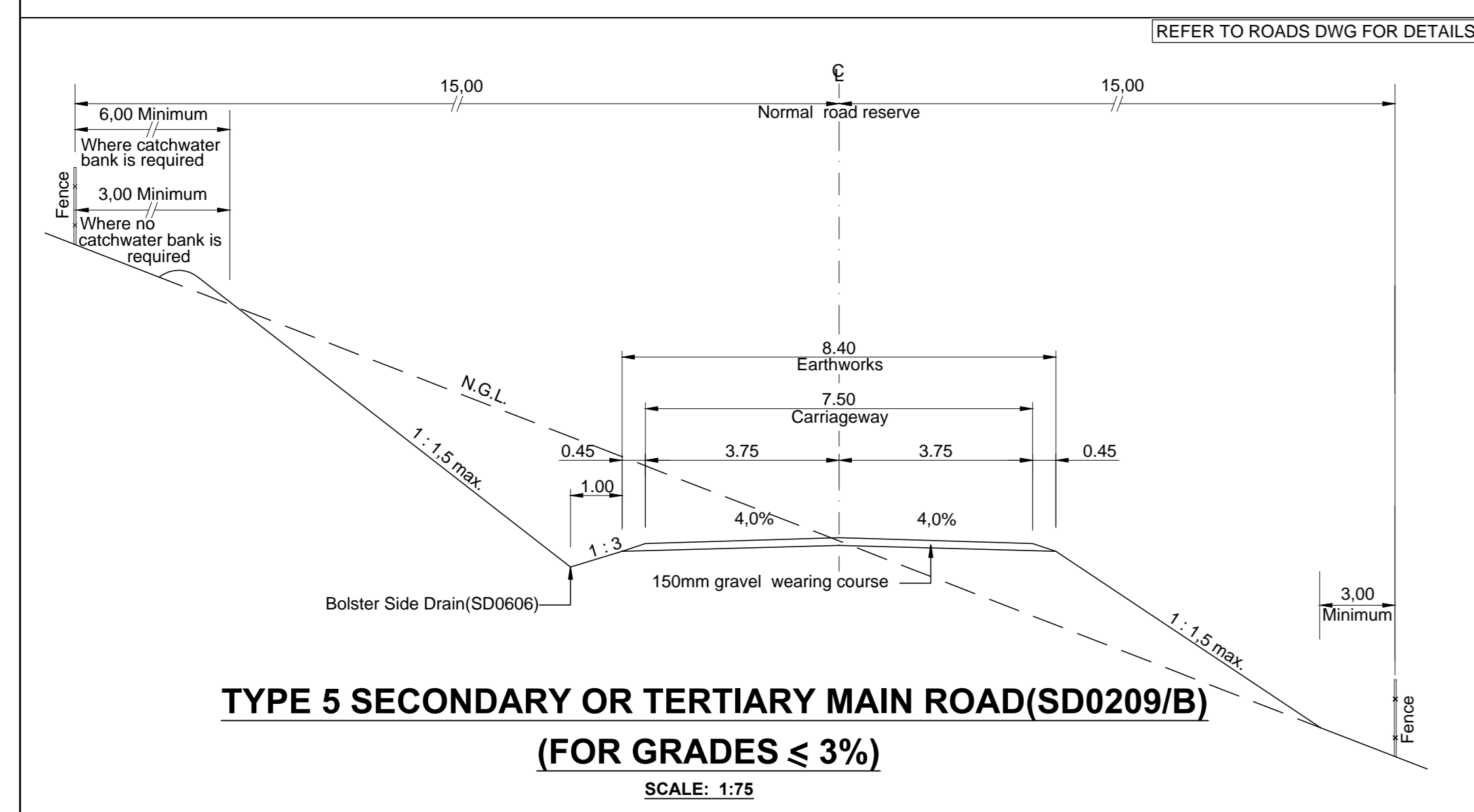
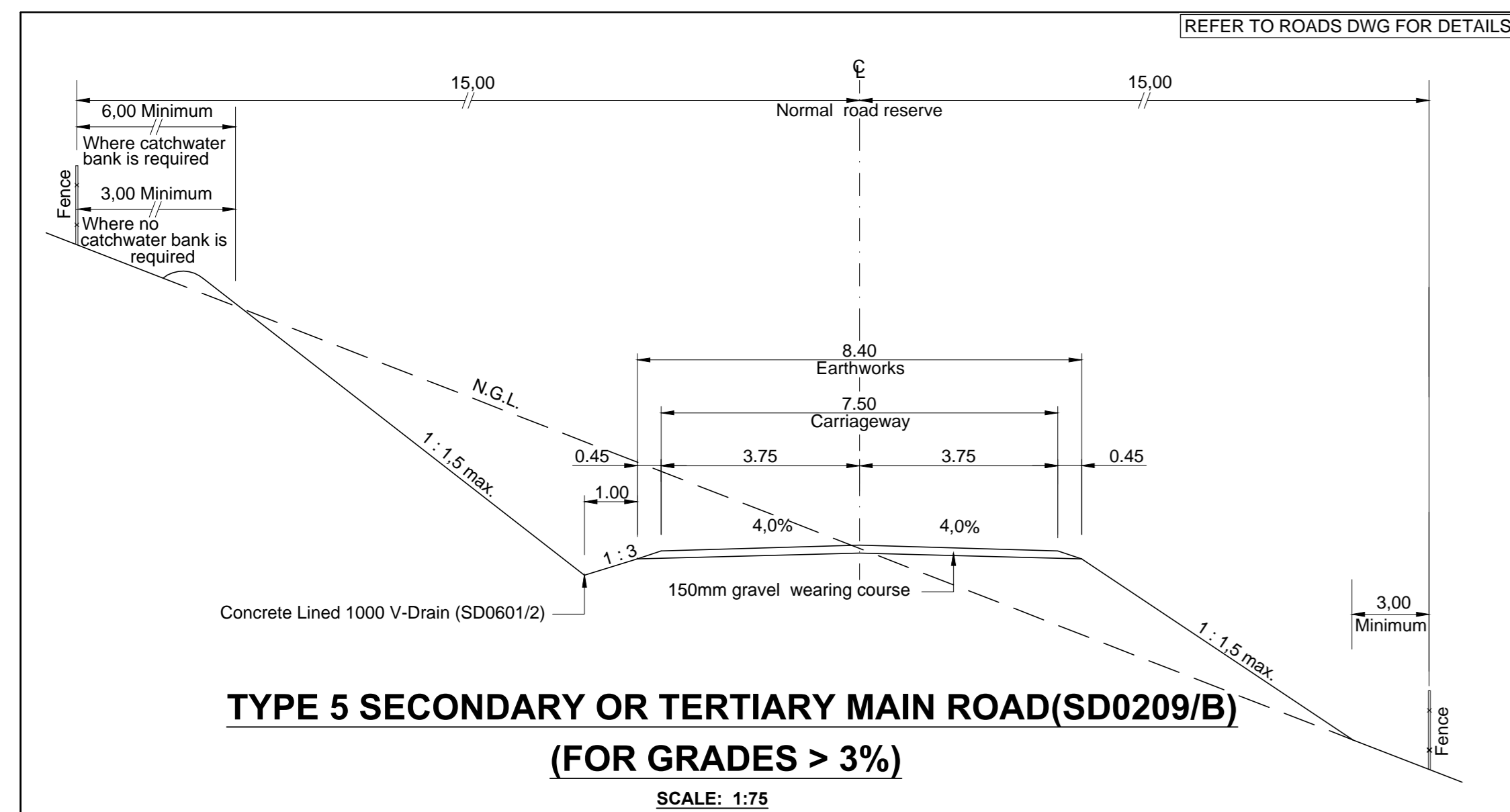

FOR TENDER PURPOSES

Symbol	Date	Description	Checked	Signed
C	01-07-21	FOR DESIGN APPROVAL	S.S	
B	24-06-21	FOR DESIGN APPROVAL	S.S	
A	20-05-21	FOR APPROVAL PURPOSES	S.S	
AMENDMENTS				

AS BUILT	
Supervising Engineer	Date
Supervising Authority	

Continued from:-	Designed by:- S.SHEOBALAK Pr Eng (202101742)
Continued on:-	Checked by:- P. NANKHOO Pr Eng (910350)
Design Plan No:-	Drawn by:- A. GUNAS
Long Section No:-	Checked by:- P. NANKHOO Pr Eng (910350)
Cross Section No:-	File Reference:- P176/6/4101/4

PROVINCE OF KWAZULU-NATAL
DEPARTMENT OF TRANSPORT

NANKHOO
CONSULTING ENGINEERS

Chief Engineer: Structural Design

Head: Transport

SIGNATURE DATE

MAIN ROAD P176 WEENEN TO MIDDELRS

WGS 84:- -28.899456° Latitude
30.084308° Longitude

PORTION
UMNGWENYA RIVER BRIDGE NO. 4101
GENERAL ARRANGEMENT C (ROAD LONGITUDINAL SECTION)

Staked km distance	Sheet 03 of 15
Scale AS SHOWN	Plan No.: 4101/03

4101/03

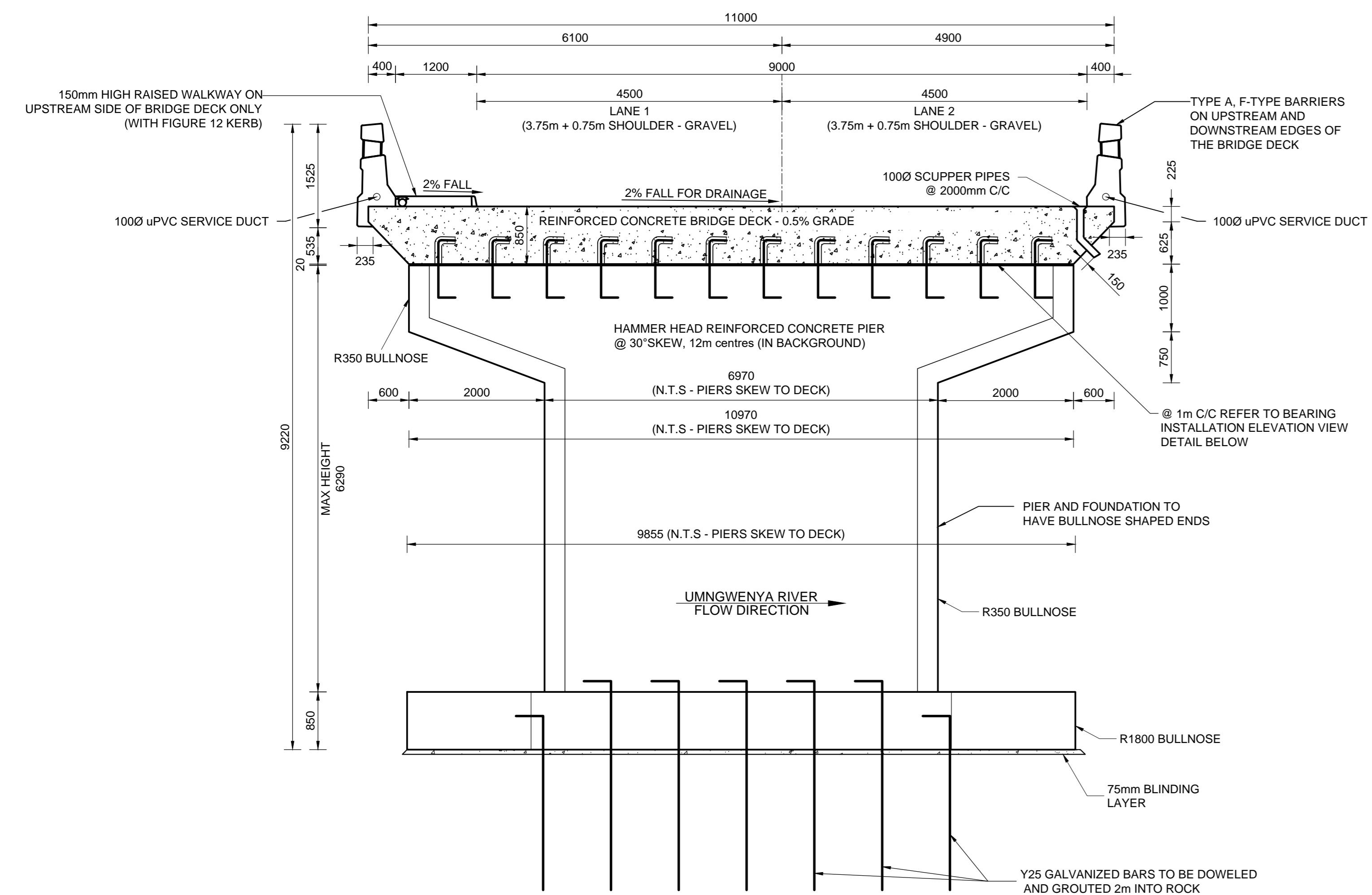

TYPICAL SECTION THROUGH DECK & ELEVATION VIEW OF PIER
SCALE (1:50)

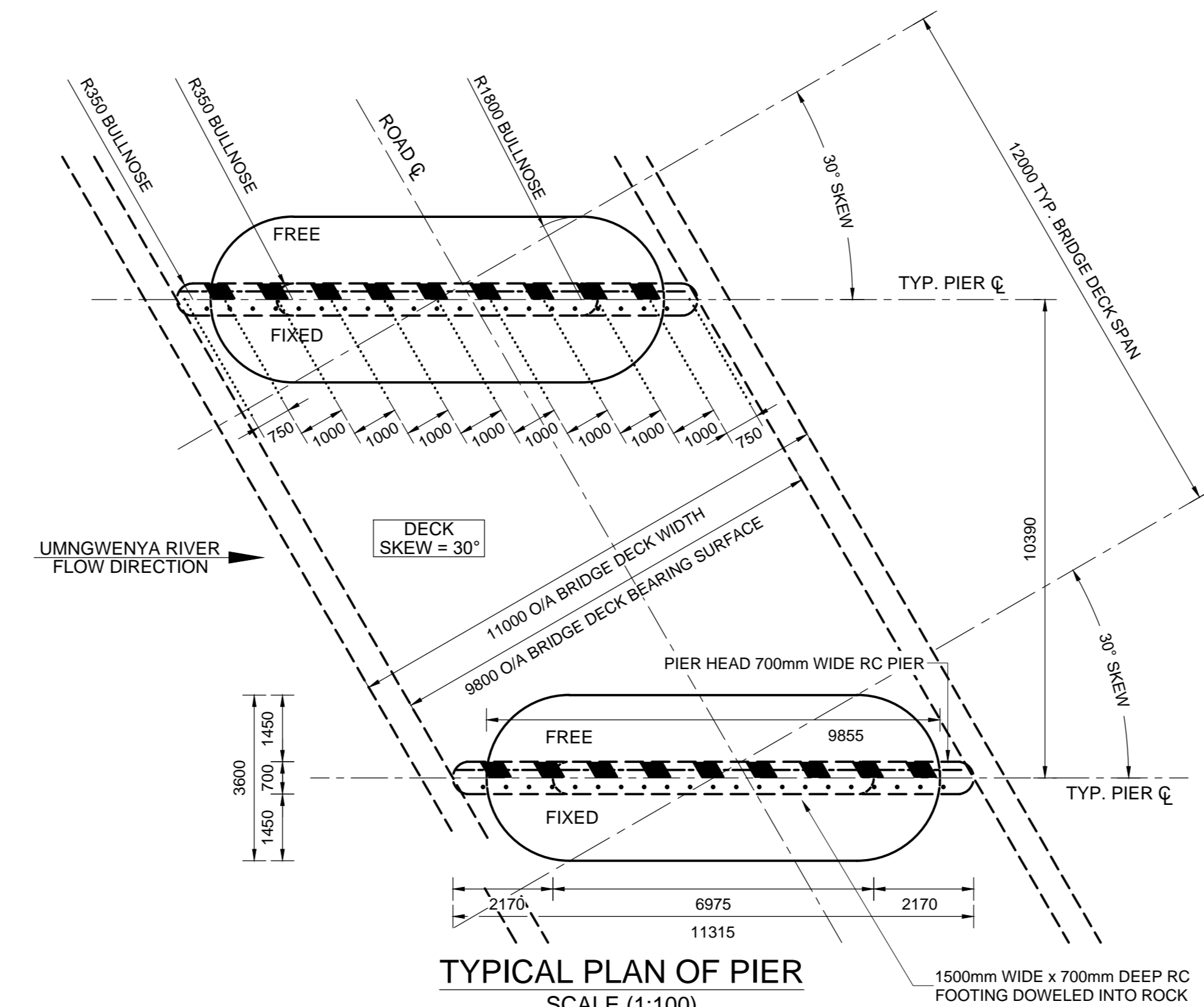

TYPICAL PLAN OF PIER
SCALE (1:100)

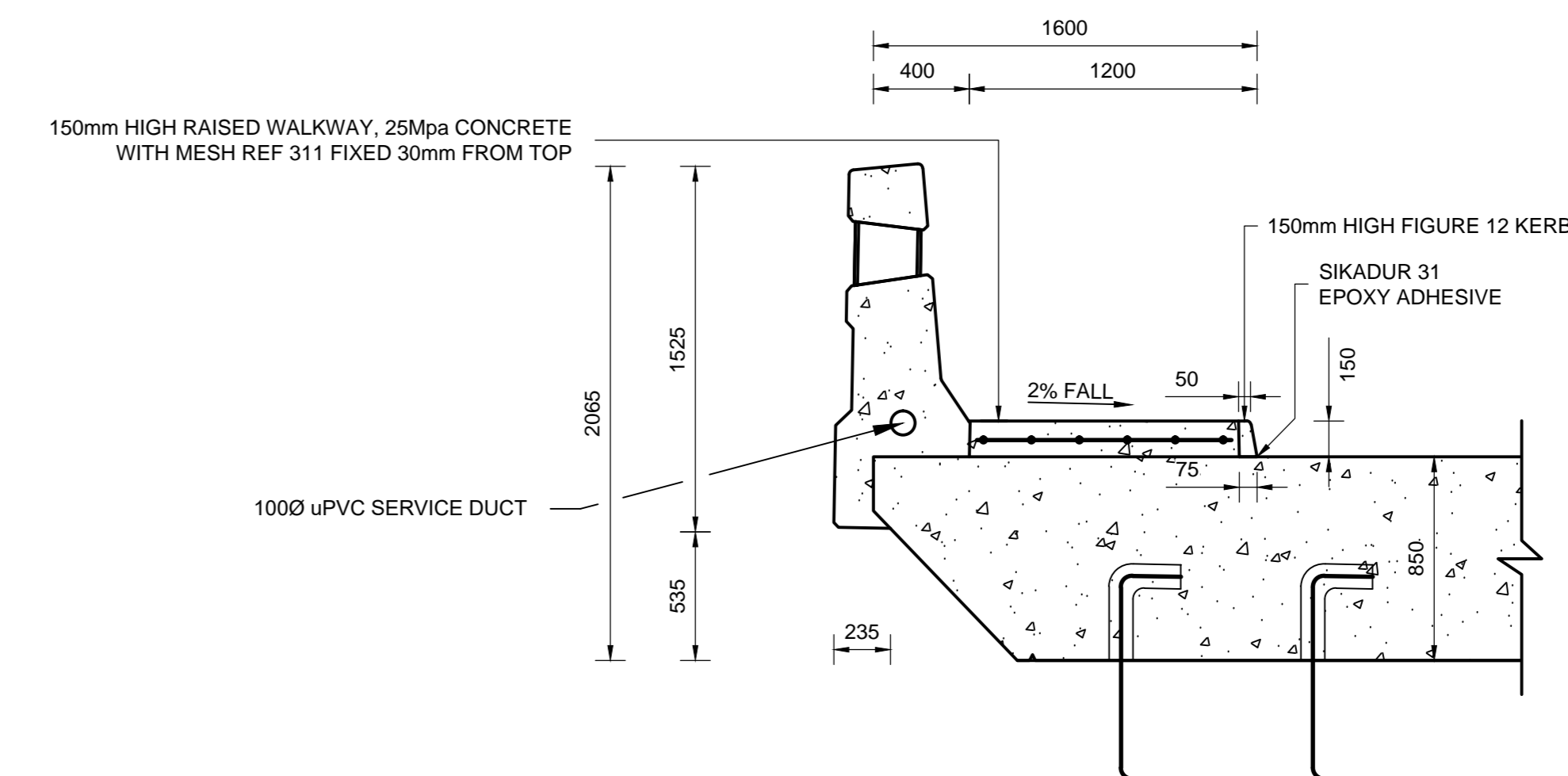

TYPICAL SECTION THROUGH DECK & WALKWAY
SCALE (1:25)

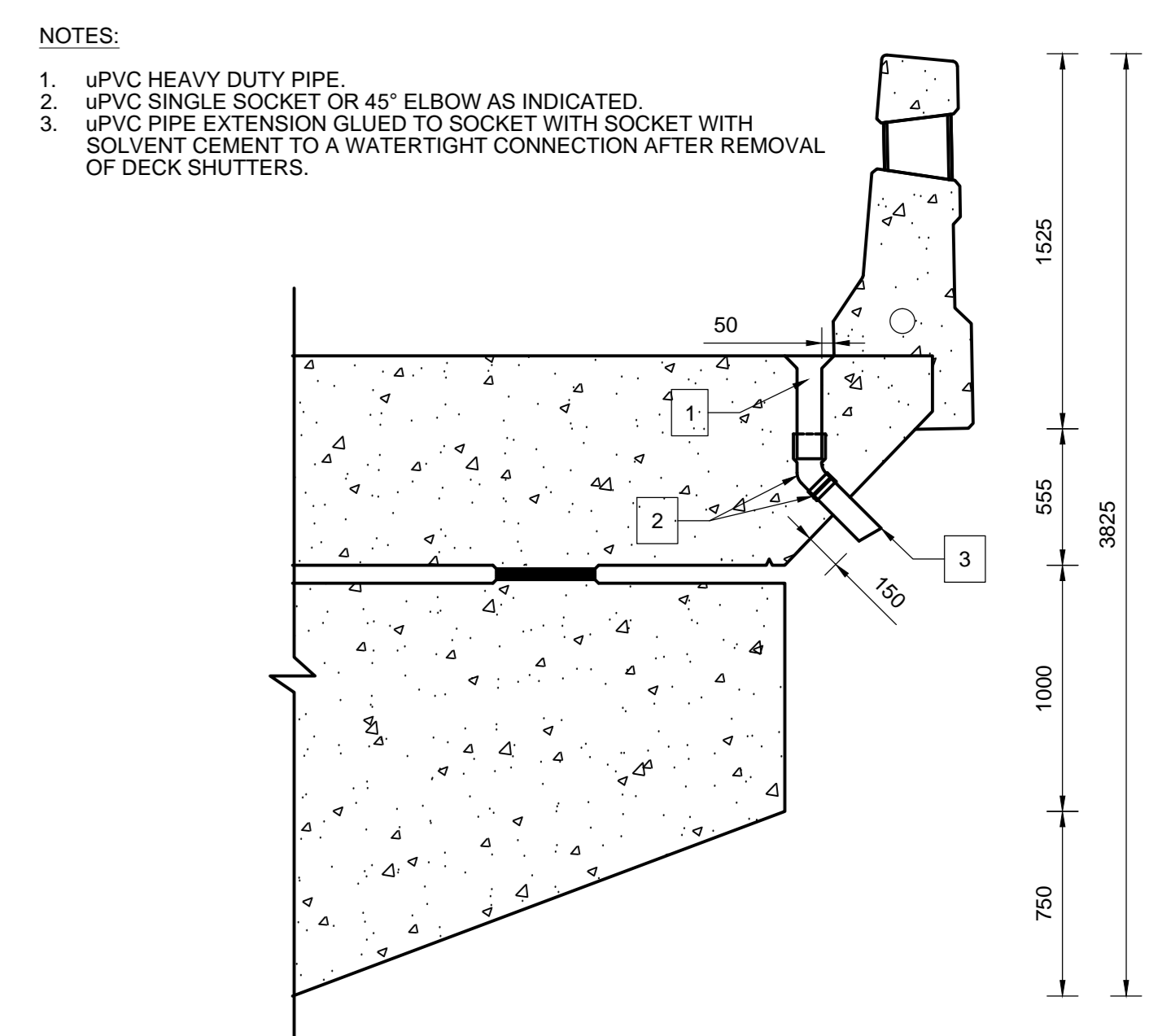

TYPE 3 DRAINAGE SCUPPER
SCALE (1:25)

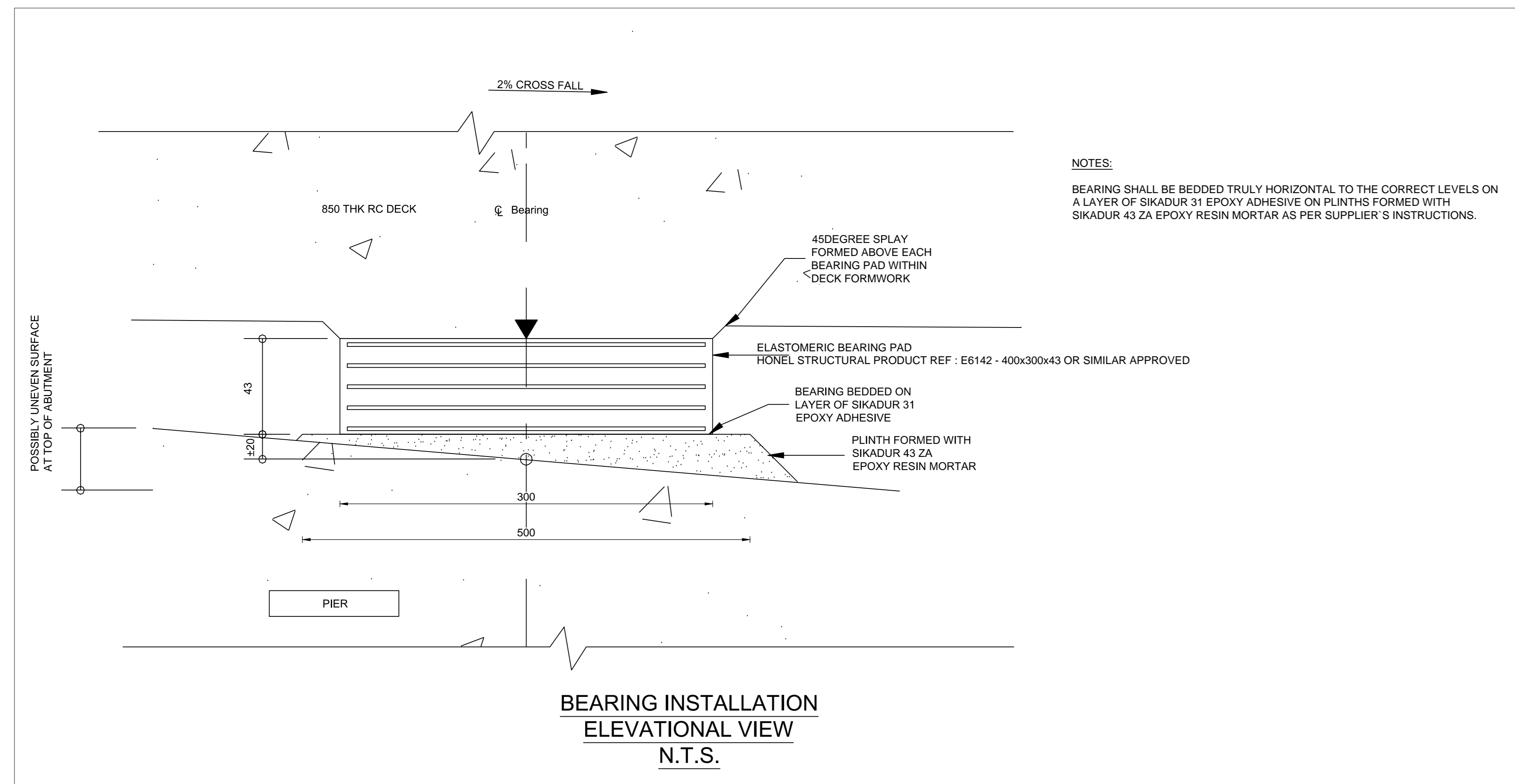

BEARING INSTALLATION
ELEVATIONAL VIEW
N.T.S.

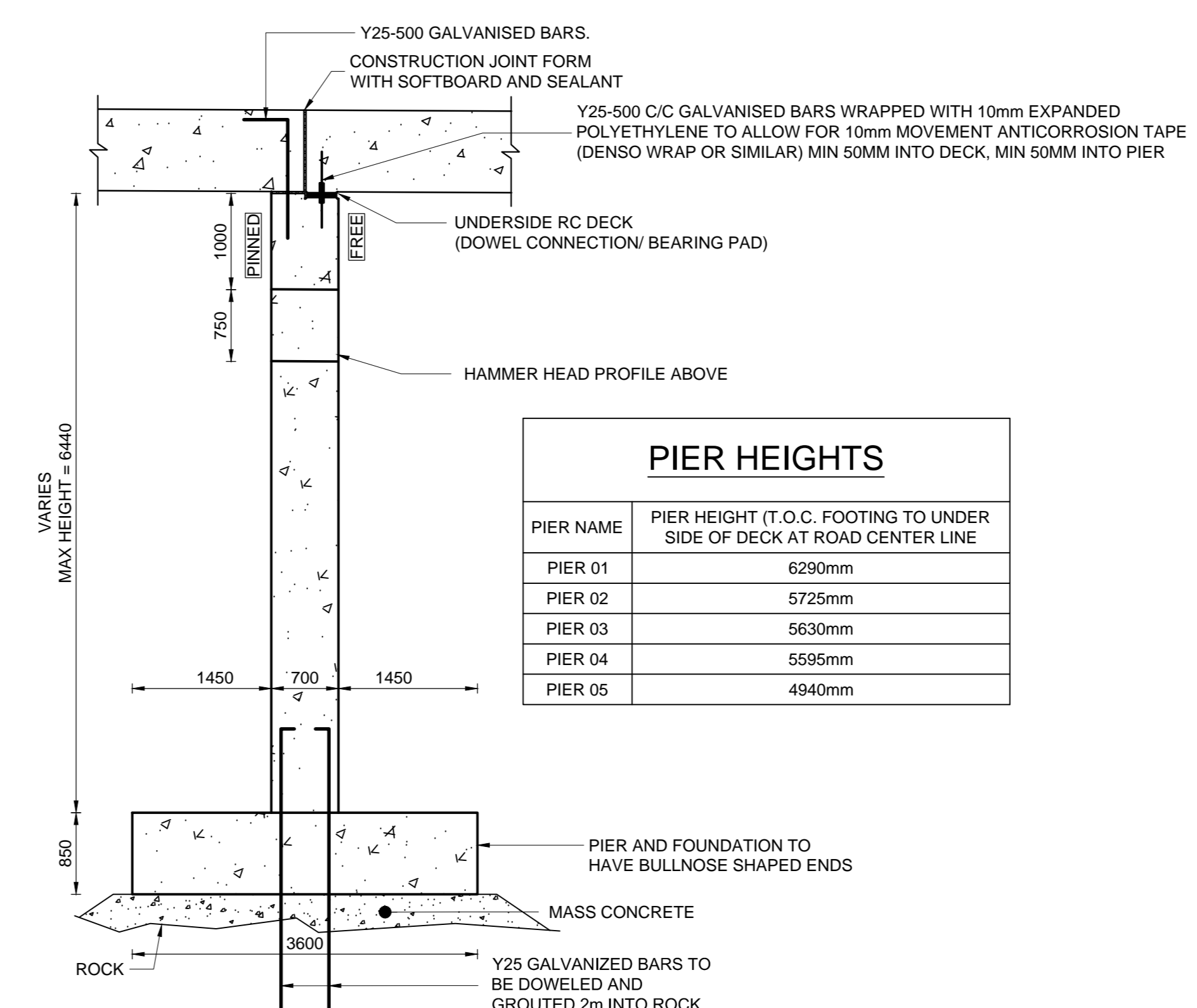

TYPICAL SECTION OF PIER
SCALE (1:50)

PIER HEIGHTS	
PIER NAME	PIER HEIGHT (T.O.C. FOOTING TO UNDER SIDE OF DECK AT ROAD CENTER LINE)
PIER 01	6290mm
PIER 02	5725mm
PIER 03	5630mm
PIER 04	5595mm
PIER 05	4940mm

NOTES:
BEARING SHALL BE BEDDED TRULY HORIZONTAL TO THE CORRECT LEVELS ON A LAYER OF SIKADUR 31 EPOXY ADHESIVE ON PLINTHS FORMED WITH SIKADUR 43 ZA EPOXY RESIN MORTAR AS PER SUPPLIER'S INSTRUCTIONS.

FOR TENDER PURPOSES

Symbol	Date	Description	Checked	Signed
E	02-08-21	FOR DESIGN APPROVAL	S.S	
D	20-07-21	FOR DESIGN APPROVAL	S.S	
C	01-07-21	FOR DESIGN APPROVAL	S.S	
B	24-06-21	FOR DESIGN APPROVAL	S.S	
A	27-05-21	FOR TENDER PURPOSES	S.S	

AS BUILT
Supervising Engineer: _____ Date: _____
Supervising Authority: _____

Continued from:-	Designed by:- S.SHEOBALAK Pr Eng (202101742)
Continued on:-	Checked by:- P. NANKHOO Pr Eng (910350)
Design Plan No:-	Drawn by:- A. GUNAS
Long Section No:-	Checked by:- P. NANKHOO Pr Eng (910350)
Cross Section No:-	File Reference:- P176/6/4101/4



PROVINCE OF KWAZULU-NATAL
DEPARTMENT OF TRANSPORT

NANKHOO
CONSULTING ENGINEERS
SHEWAN TOMES BUILDING, 100 WATERLOO STREET, DURBAN, KZN 4001
TEL: 031 201 1000 FAX: 031 201 1001
WWW.NANKHOOCENGINERS.CO.ZA

Chief Engineer: Structural Design
Head: Transport
SIGNATURE: _____ DATE: _____

MAIN ROAD P176 WEENEN TO MIDDELRSUS
WGS 84: -28.899456° Latitude
30.084308° Longitude
Staked km distance: 5.1KM
Scale: AS SHOWN
Plan No.: 4101/04

Sheet 04 of 15
Scale AS SHOWN
Plan No.: 4101/04

4101/04

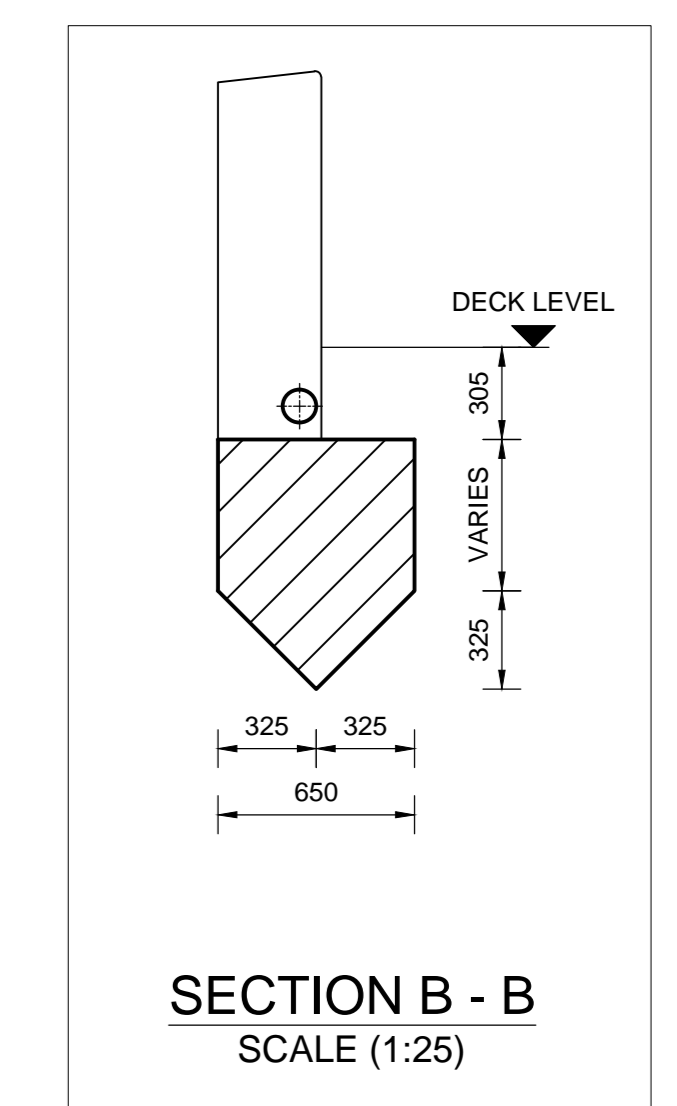
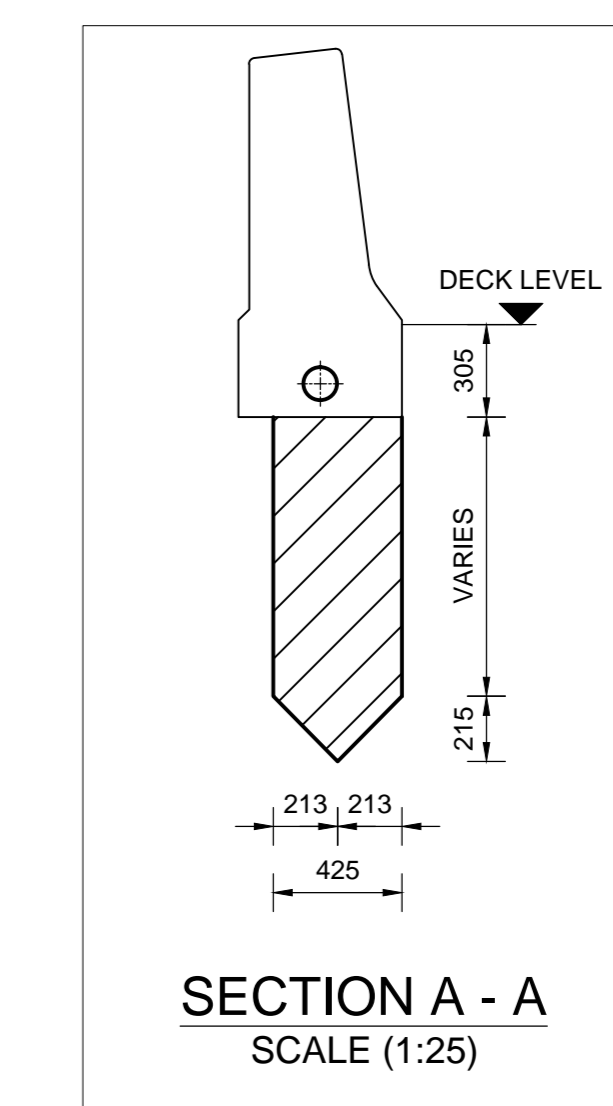
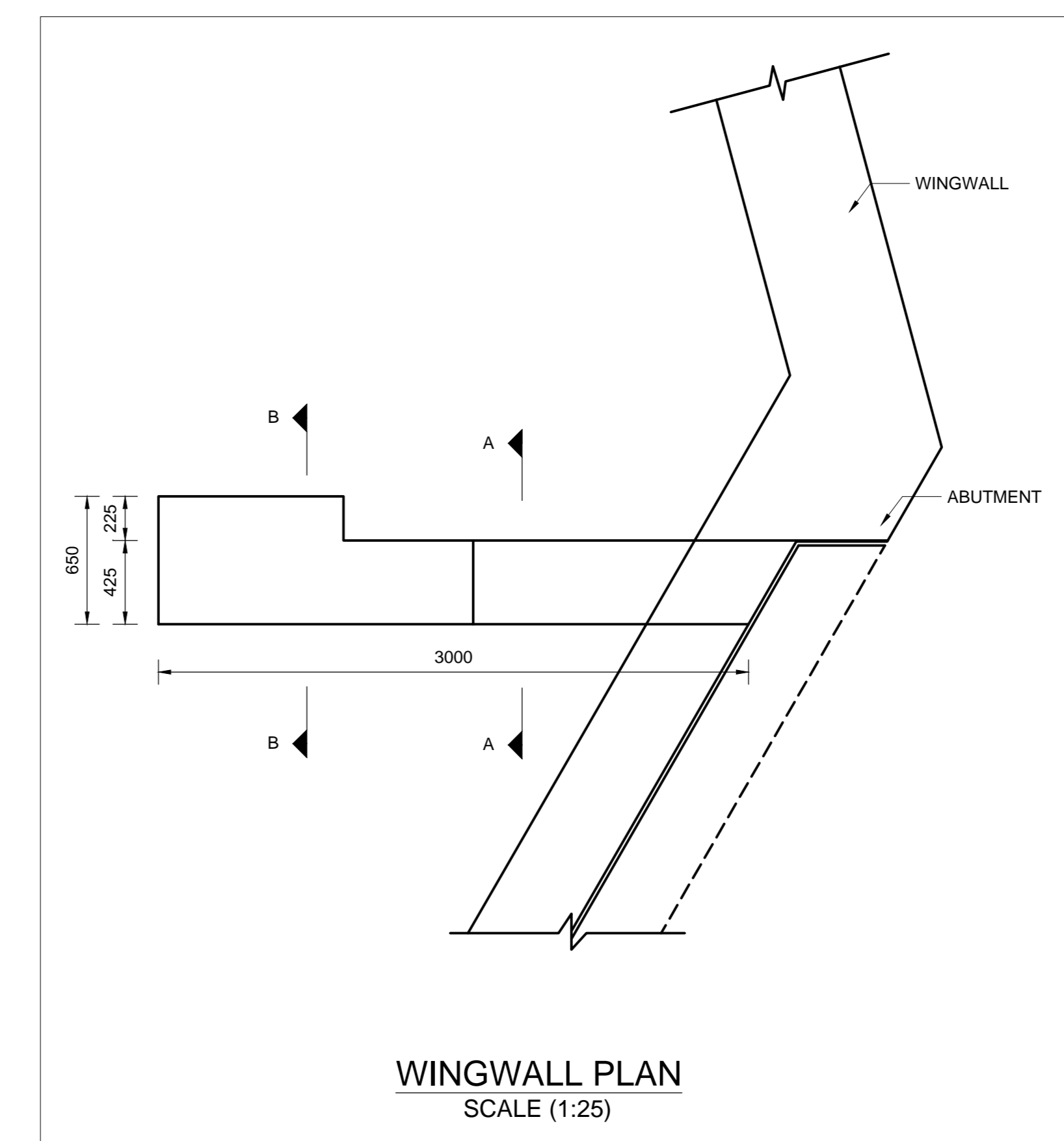
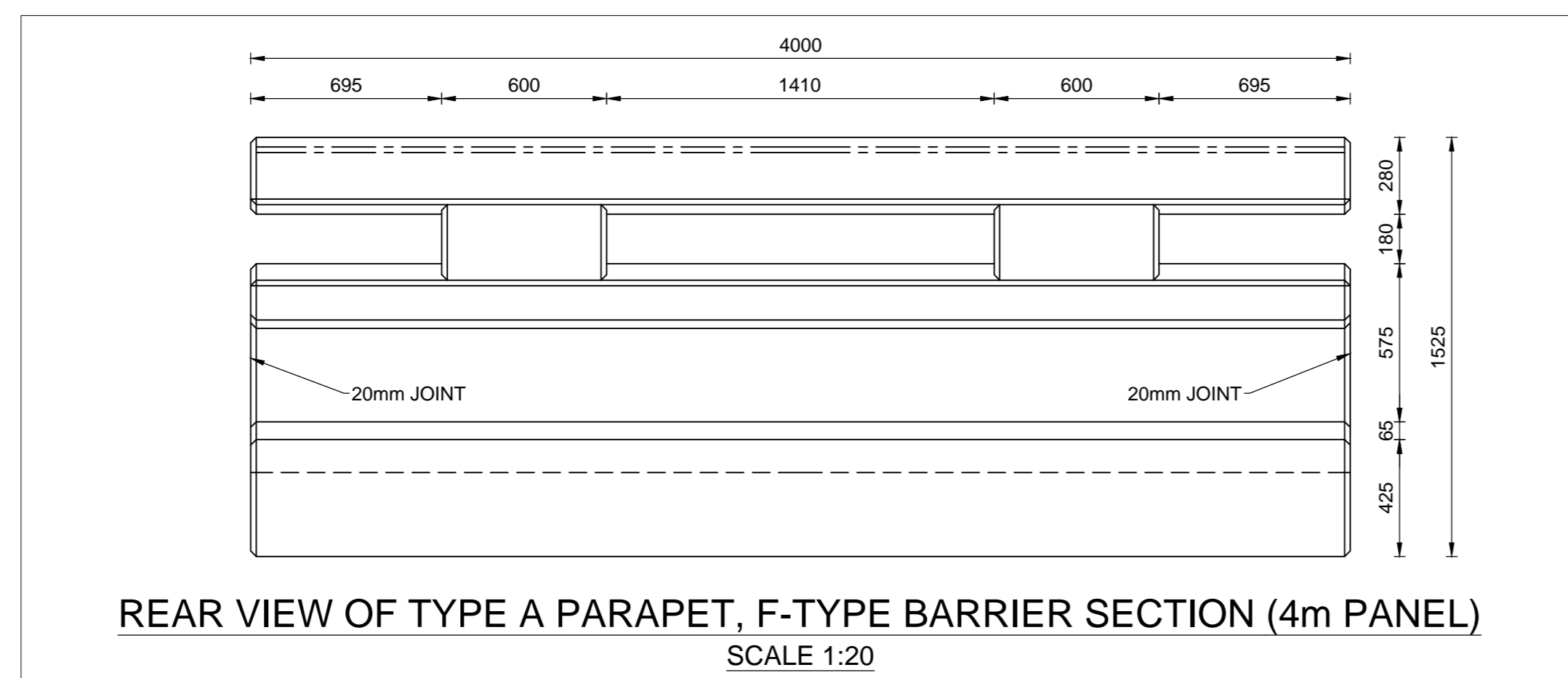
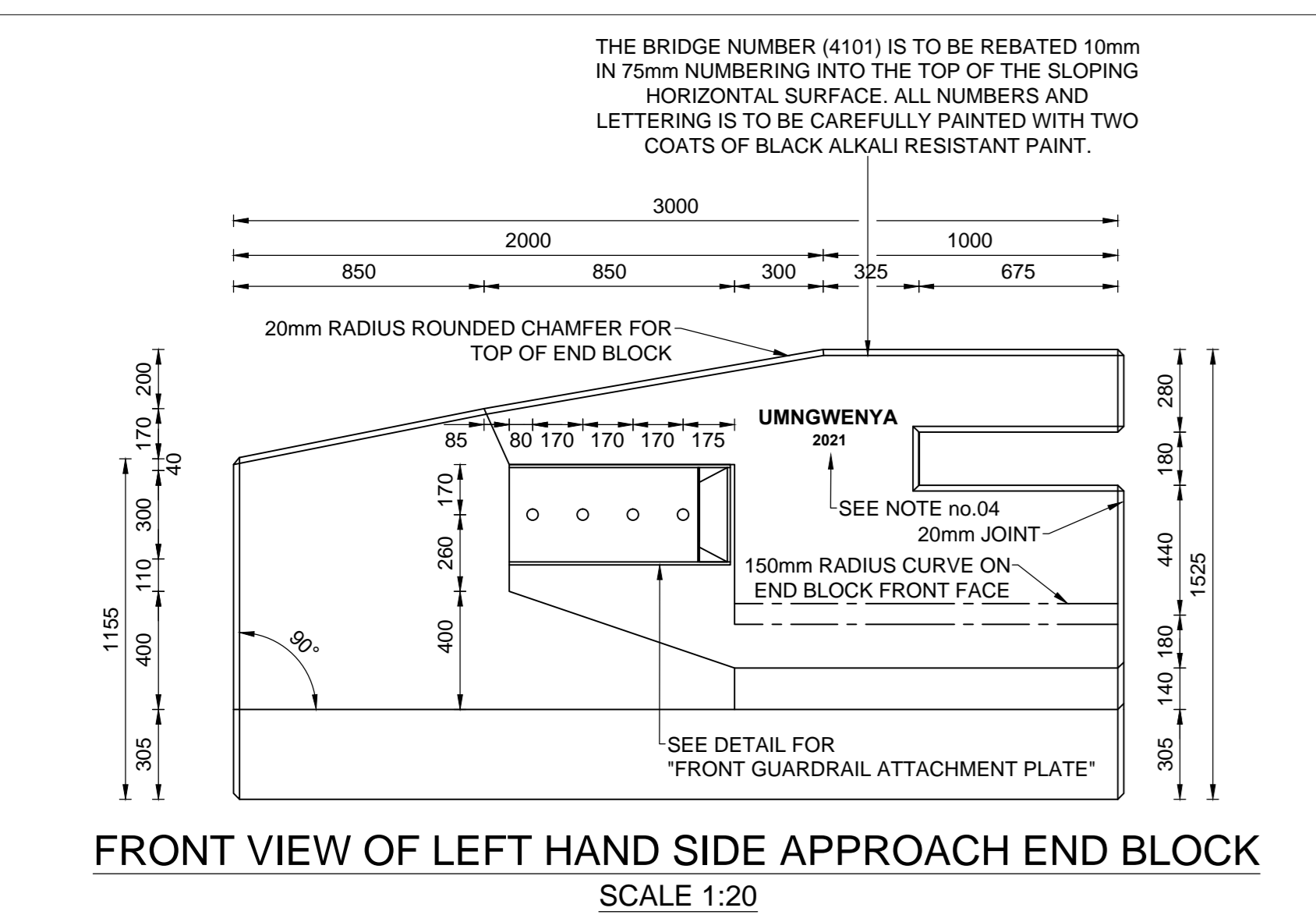
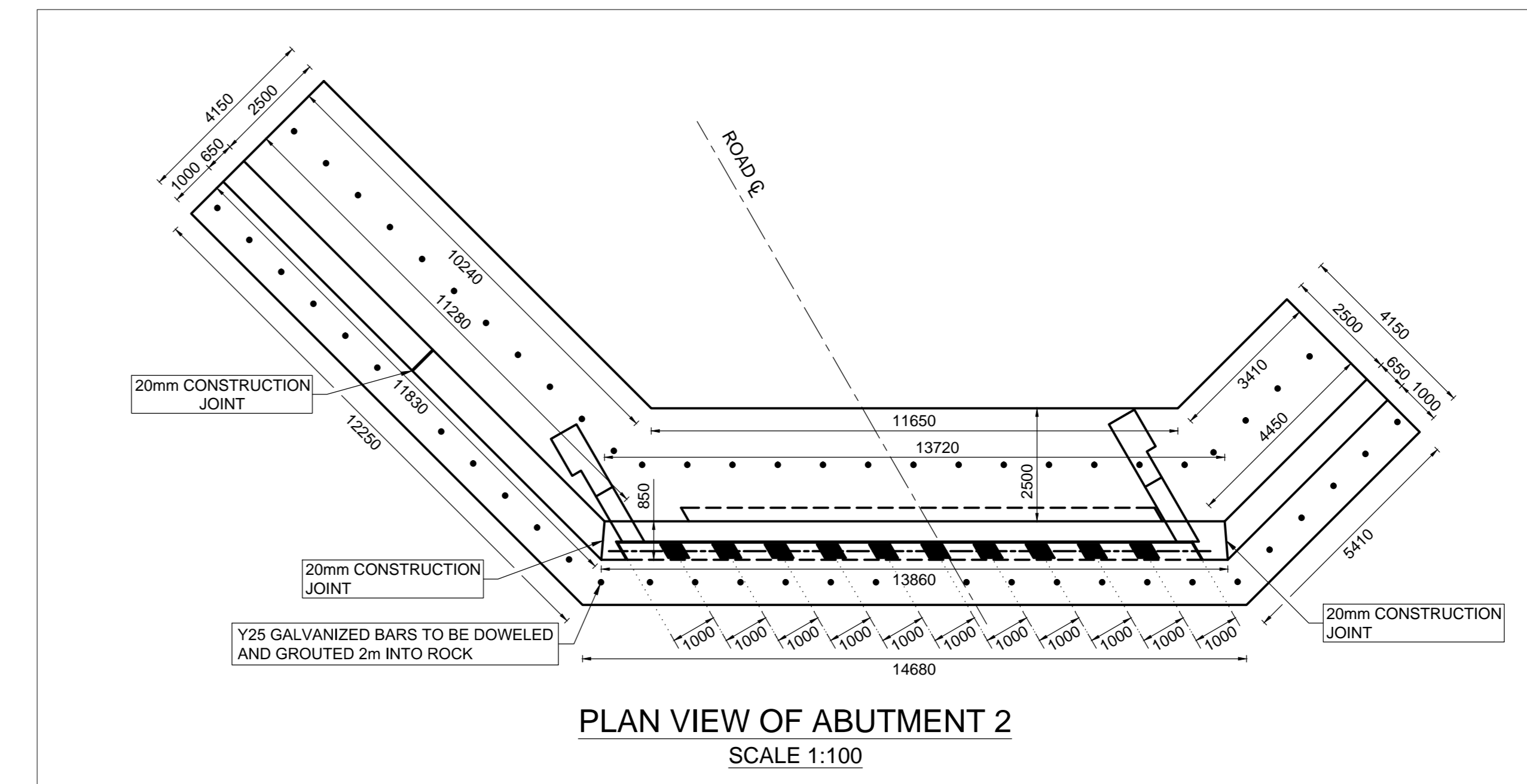
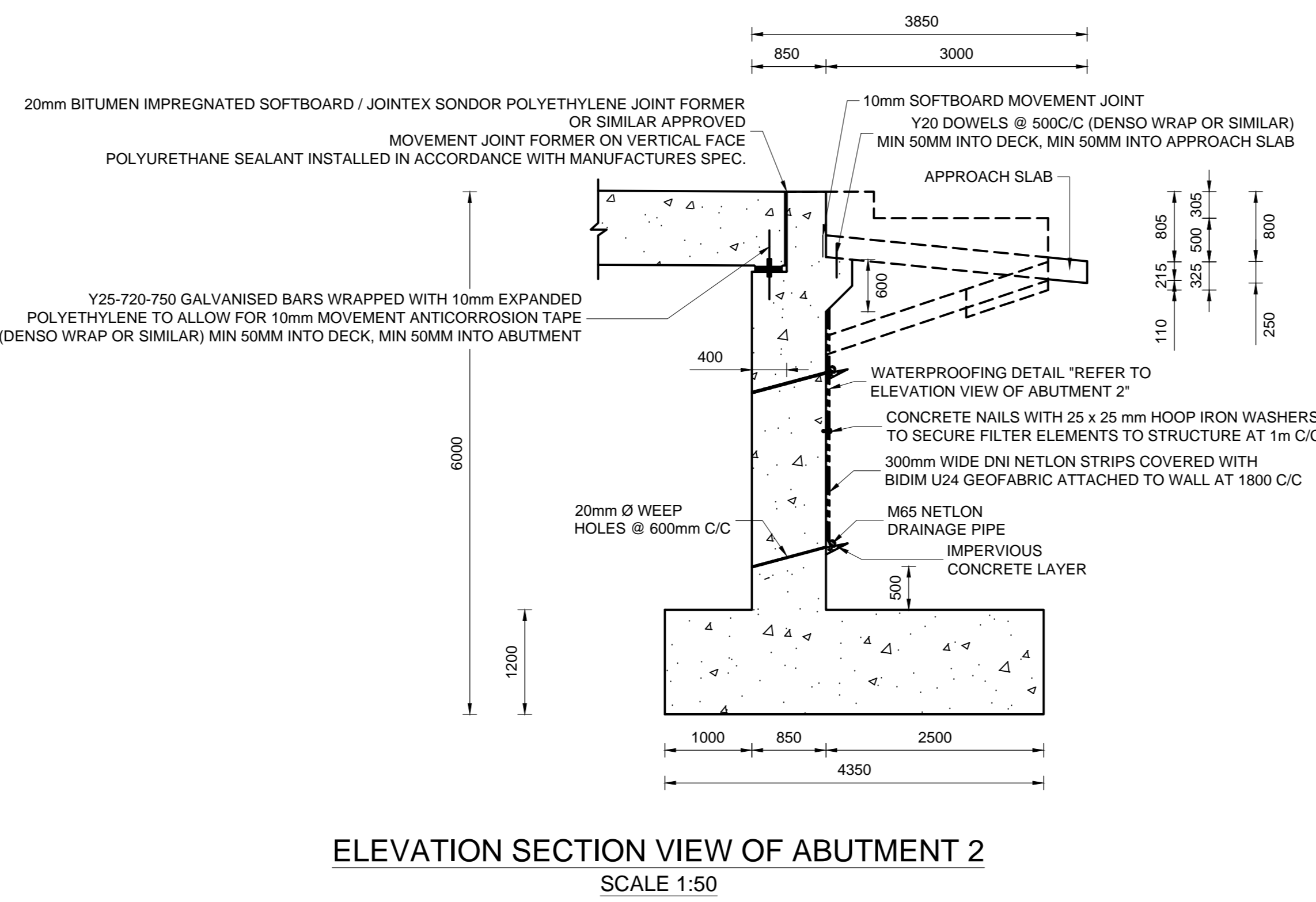
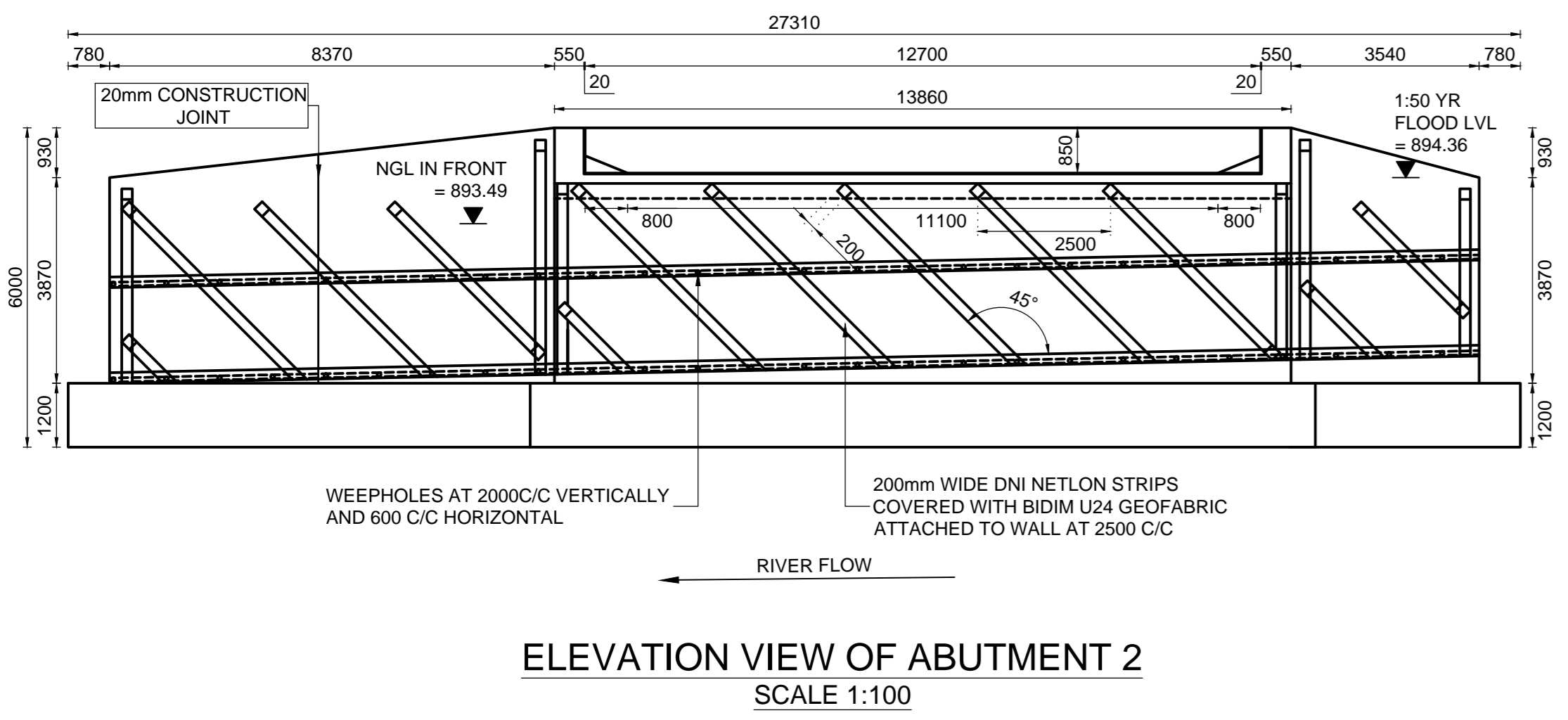
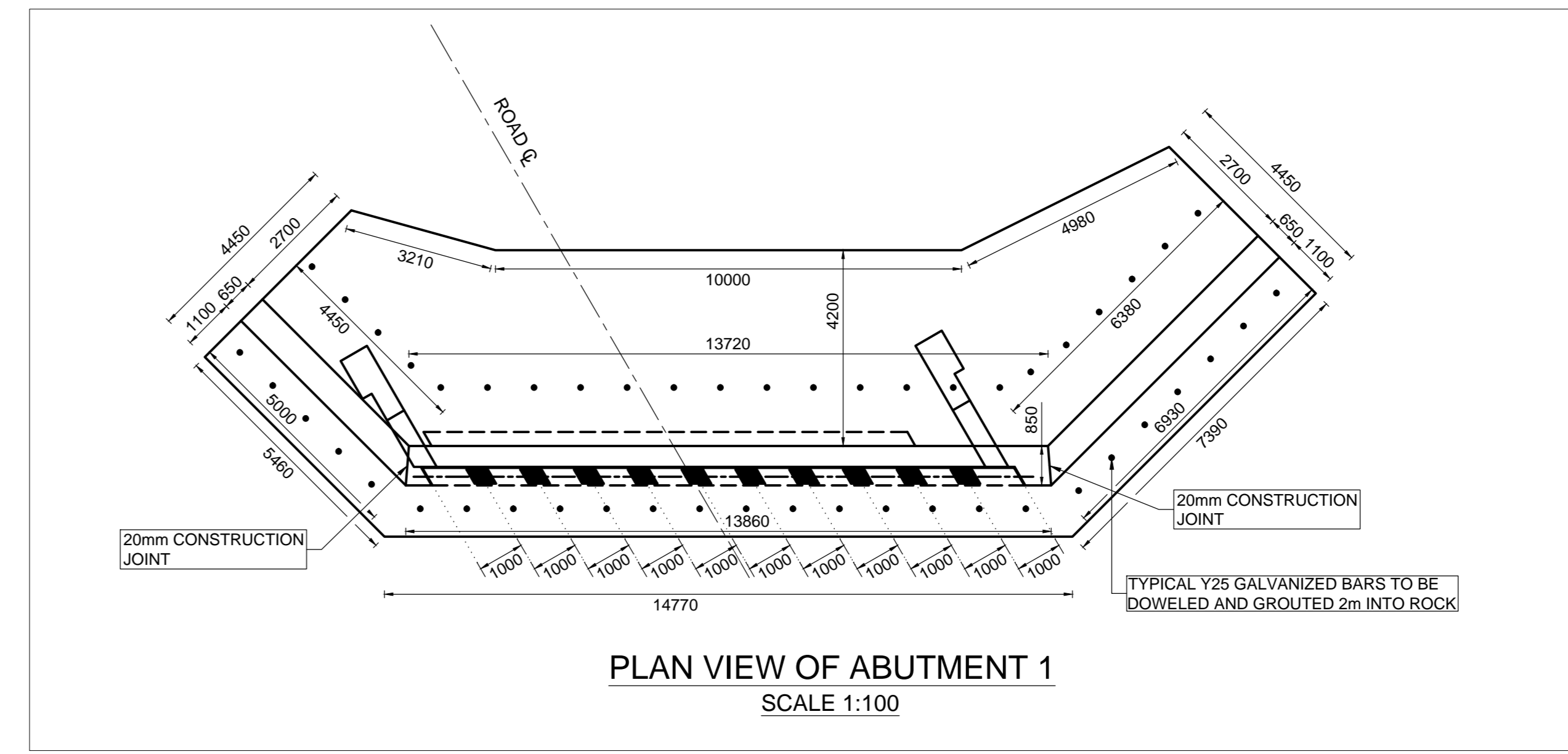
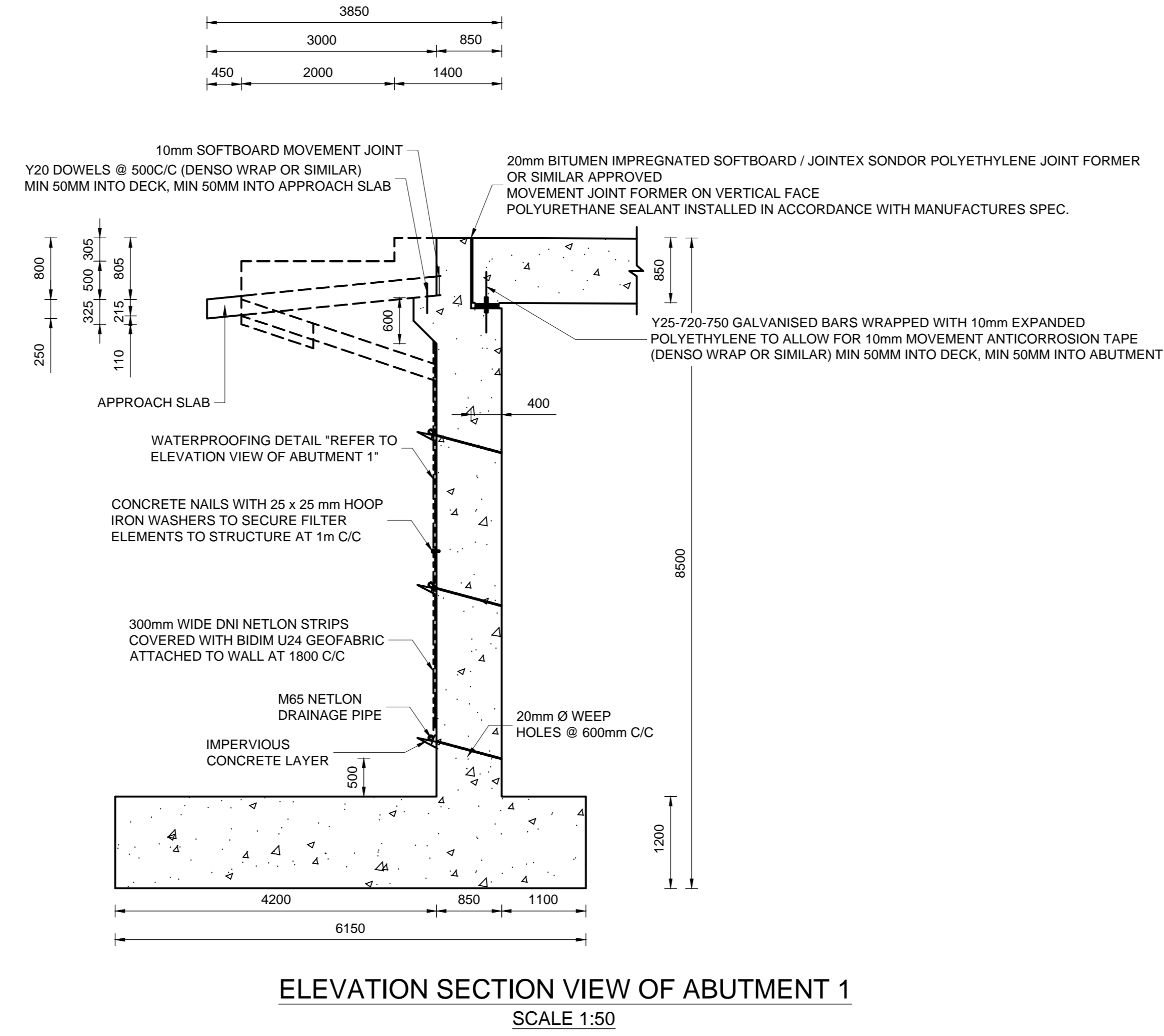
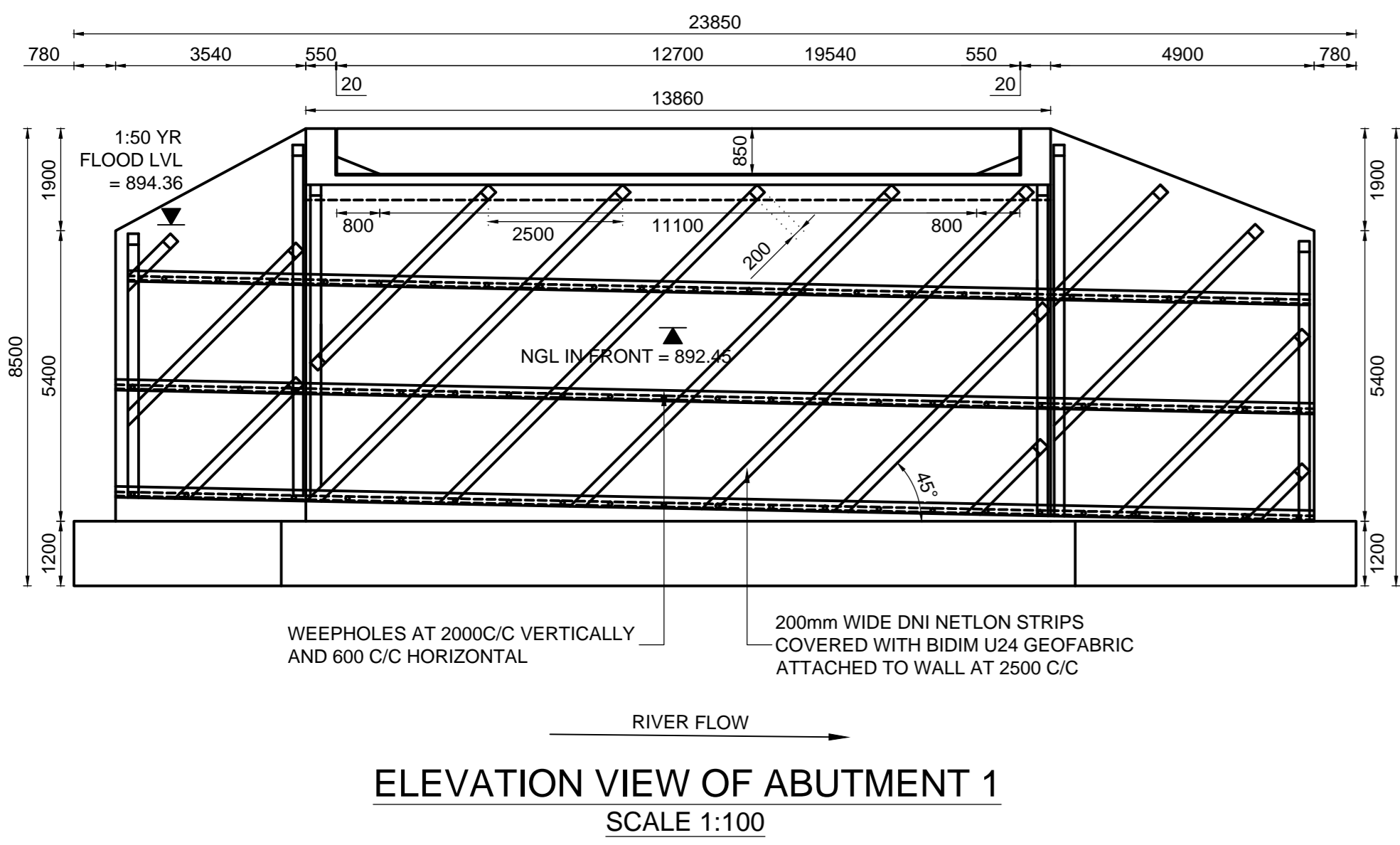

Symbol	Date	Description	Checked	Signed
E	02-08-21	FOR DESIGN APPROVAL	S.S	
D	20-07-21	FOR DESIGN APPROVAL	S.S	
C	01-07-21	FOR DESIGN APPROVAL	S.S	
B	24-06-21	FOR DESIGN APPROVAL	S.S	
A	27-05-21	FOR TENDER PURPOSES	S.S	
AMENDMENTS				

AS BUILT

Supervising Engineer: _____ Date: _____

Supervising Authority: _____

Continued from:-	Designed by:- S.SHEOBALAK Pr Eng (202101742)
Continued on:-	Checked by:- P. NANKHOO Pr Eng (910350)
Design Plan No:-	Drawn by:- A. GUNAS
Long Section No:-	Checked by:- P. NANKHOO Pr Eng (910350)
Cross Section No:-	File Reference:- P176/6/4101/4

PROVINCE OF KWAZULU-NATAL
DEPARTMENT OF TRANSPORT

NANKHOO
CONSULTING ENGINEERS

Chief Engineer: Structural Design

Head: Transport

SIGNATURE _____ DATE _____

MAIN ROAD P176 WEENEN TO MIDDELRSUS

WGS 84:- -28.899456° Latitude
30.084308° Longitude

PORTION
UMNGWENYA RIVER BRIDGE NO. 4101
GENERAL ARRANGEMENT E (ABUTMENT & BARRIER DETAIL)

FOR TENDER PURPOSES

Staked km distance: 5.1KM

Scale: AS SHOWN

Sheet 05 of 15

Plan No.: 4101/05

4101/05